

Specification: HE10000STL		
1	Package	SMD (7 mm x 5 mm x 1.7 mm)
2	Type	SPXO (With Tristate)
3	Frequency	100.0000 MHz
4	Stability	±50 ppm max/0~+70°C
5	Voltage	+3.3 v ± 5 %
6	Current	66 mA max
7	Output Signal	LVDS
	V_{OH}	1.43 v (Typ)
	V_{OL}	1.10 v (Typ)
8	Output load	100 Ω (Offset 1.25 Typ)
9	Rise and Fall	0.7 nsec max
10	Symmetry	40% to 60%
11	Jitter	1 ps
	Note:	RoHS Compliant

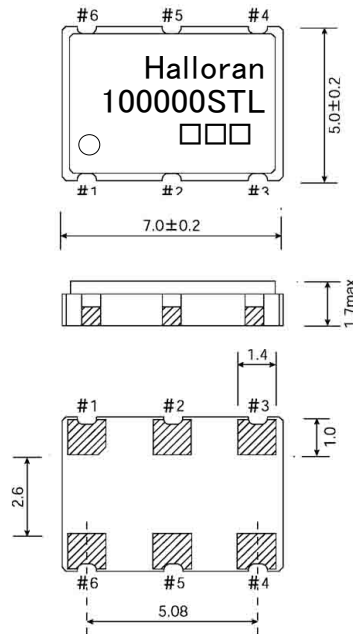

■ 外形寸法 Dimensions

■ 接続端子

Pin Connections	
①	En/Disable
②	NC
③	Vss
④	Output
⑤	Output
⑥	Vcc

Test Circuit

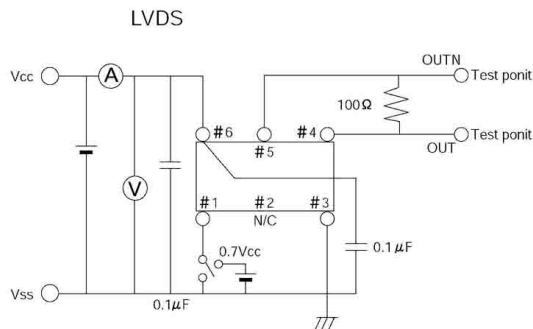

Output Waveform

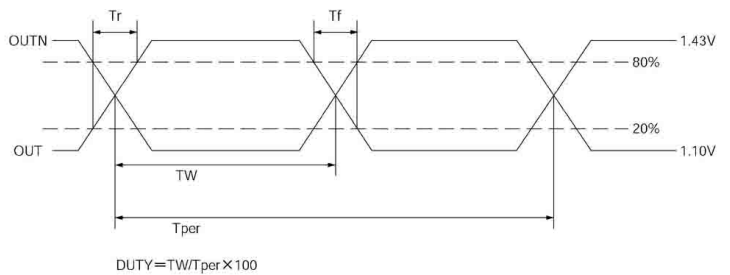

Enable-disable

input pin #1	output pin #4 #5
open or 70 % V_{CC} min	RF-signal
GND or 30 % V_{CC} max	HI-Z
Enable Phase Delay time 2 ms max	
Disable Phase Delay Time 200 ns max	