

Specification: HE100800SUD		
1	Package	SMD (5 mm x 3.2 mm x 1.1 mm)
2	Type	SPXO (With Tristate)
3	Frequency	100.8000 MHz
4	Stability	±30 ppm max/0~+70°C
5	Voltage	+3.3 v ± 5 %
6	Symmetry	45% to 55%
		CMOS (15 pF)
7	Pullability	NA
	Note:	

■ 外形寸法 Dimensions

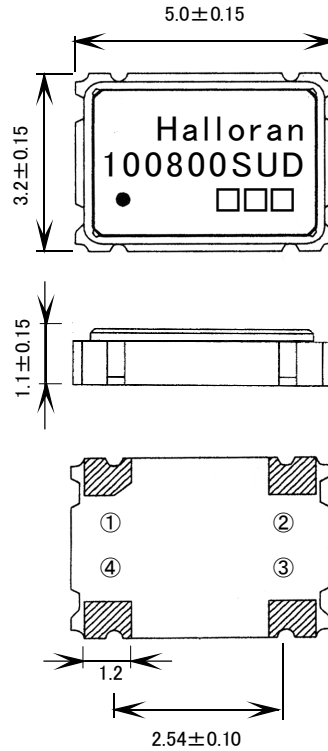

■ 接続端子 Pin Connections

①	$\overline{\text{INH}}$
②	GND (V_{SS})
③	Output
④	+3.3 v (V_{DD})

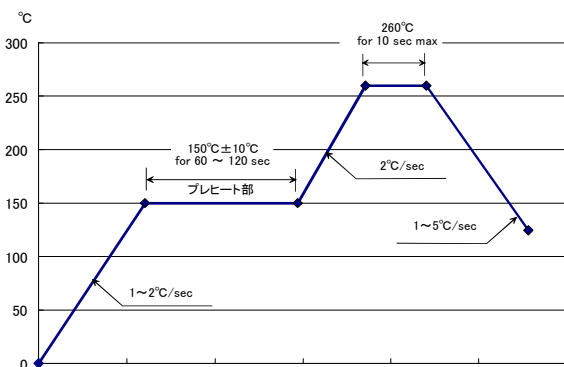

測定回路 CMOS出力

